

# PYROLINE HS 512N/2000 Hz

High-speed non-contact measurement of temperature profiles up to 3000 °C



- ✓ Precise non-contact temperature measurement with extremely wide temperature ranges:  
650 °C to 1500 °C, optional 1400 °C to 3000 °C
- ✓ High-dynamic Si-CMOS array with 512 × 1 pixels
- ✓ Numerous optics with motor focus
- ✓ Spectral range 0.8 μm to 1.1 μm
- ✓ Fast Ethernet interface
- ✓ Measurement frequency 2000 lines per second
- ✓ Large dynamic range and 16-Bit analog digital converter
- ✓ Camera in small housing "compact+" (IP54) or industry protection housing "protection" (IP65)
- ✓ Integration in customized system solutions including hard- and software adjustment

## Overview

Whether in quality control, process monitoring or process automation in metal industry – the infrared camera PYROLINE HS 512N measures temperatures without contact exactly and reliably. To minimize physically caused temperature measurement errors resulting from emissivity inaccuracies the camera works at a short wavelength range from 0.8 μm to 1.1 μm. Also in very fast processes or at temperature changes the data acquisition happens in real-time.

In stationary industrial continuous operation measurement data is recorded with high thermal and spatial resolution on fixed or moving measurement objects. In this way production processes are monitored and controlled efficiently. Therefore the Fast Ethernet interface guarantees a data acquisition without loss and with no appreciable time delay up to 2000 lines per second.

Numerous motor focus infrared lenses, including wide angle and telephoto lenses, provide a flexible adjustment to different measurement object sizes at different measurement distances.

The infrared camera is either built in a small aluminium housing "compact+" or in a stainless steel industry protection housing "protection" that has an air purge unit and watercooling by default.

The camera observes the production in stand-alone operation without any connected computer via two galvanically isolated digital inputs and outputs. All process parameters of the stand-alone version are programmed once on location via PC connection.

The modular Windows software PYROSOFT of the camera can be adjusted and extended to process-related requirements. The free software PYROSOFT Compact is delivered with every PYROLINE infrared camera.

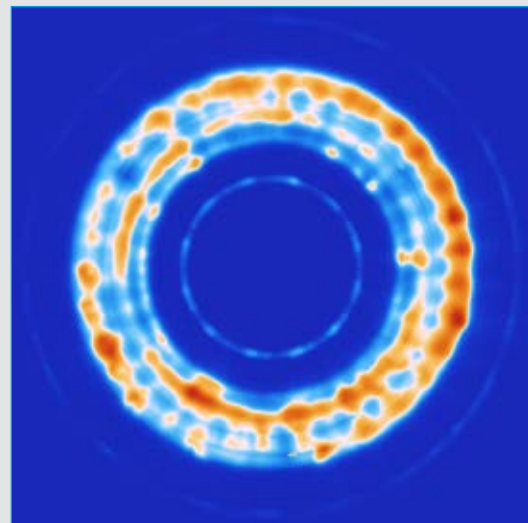

## Made by DIAS Infrared

DIAS Infrared headquartered in Dresden (Germany) develops and manufactures high-quality precision devices as well as system solutions for non-contact temperature measurement. Challenging projects are a welcoming motivation for us. The customers appreciate the robust make, outstanding accuracy, superb reliability and the high service standard of our equipment technology.

# PYROLINE HS 512N/2000 Hz

High-speed non-contact measurement of temperature profiles up to 3000 °C

Technical data				
Device type	512N/2000 Hz compact+		512N/2000 Hz protection	
Continuous measuring temperature range <sup>1</sup>	650 °C to 1500 °C	1400 °C to 3000 °C	650 °C to 1500 °C	1400 °C to 3000 °C
NETD <sup>2,3</sup>	< 1 K (650 °C, 2 kHz) <sup>4</sup>	≈ 2 K (1400 °C, 2 kHz) <sup>4</sup>	< 1 K (650 °C, 2 kHz) <sup>4</sup>	≈ 2 K (1400 °C, 2 kHz) <sup>4</sup>
Spectral range	0.8 μm to 1.1 μm			
Aperature angle (HFOV × VFOV)	36° × 0.15°, optional: 90° × 0.34°, 51° × 0.2°, 19° × 0.08°, 13° × 0.05°, 9° × 0.04° (optics with motor focus)			
Sensor	high-dynamic Si-CMOS array (512 × 1 pixels)			
Measurement uncertainty <sup>3</sup>	1 % of measured value °C	2 % of measured value °C	1 % of measured value °C	2 % of measured value °C
Maximum line frequency	2000 Hz			
Response time	internal 1 ms , selectable: 2/ measurement frequency			
Interfaces	Fast Ethernet (real-time, 2000 Hz), galvanically isolated digital inputs (trigger) and digital outputs (alarm)			
Connectors	round plug connector HR10A (12 pin, power supply, digital inputs and outputs), round plug connector M12A (Ethernet)		round plug connector M23 (16 pin, power supply, digital inputs and outputs), round plug connector M12A (Ethernet)	
Power supply	12 V to 36 V DC, typical 10 VA			
Weight	approx. 1.6 kg		approx. 4.2 kg	
Housing	aluminium compact housing IP54, 65 mm (L) × 160 mm (W) × 79 mm (H), without lens and connectors, optional with weather protection housing with pan-tilt-unit		industry protection housing IP65, stainless steel, with air purge and water cooling, diameter 110 mm, length 280 mm (without mechanical mounting and connectors), 6 bar max. water pressure, 2 bar max. air pressure, protection window	
Operating temperature of the camera	-10 °C to 50 °C		-10 °C to 50 °C (without water cooling), -25 °C to 150 °C (with water cooling)	
Storage conditions	-20 °C to 70 °C, max. 95 % rel. humidity			
Software	control and imaging software PYROSOFT for Windows®, customized modifications on request			
Scope of delivery	infrared line camera PYROLINE HS 512N, calibration certificate, manual, software PYROSOFT Compact			

<sup>1</sup> Others on request. <sup>2</sup> Noise equivalent temperature difference. <sup>3</sup> Specifications for black body radiator and ambient temperature 25 °C. <sup>4</sup> ... or 0.15 % of measured value in °C, 256 Hz.

## Lens variants (optics with motor focus)

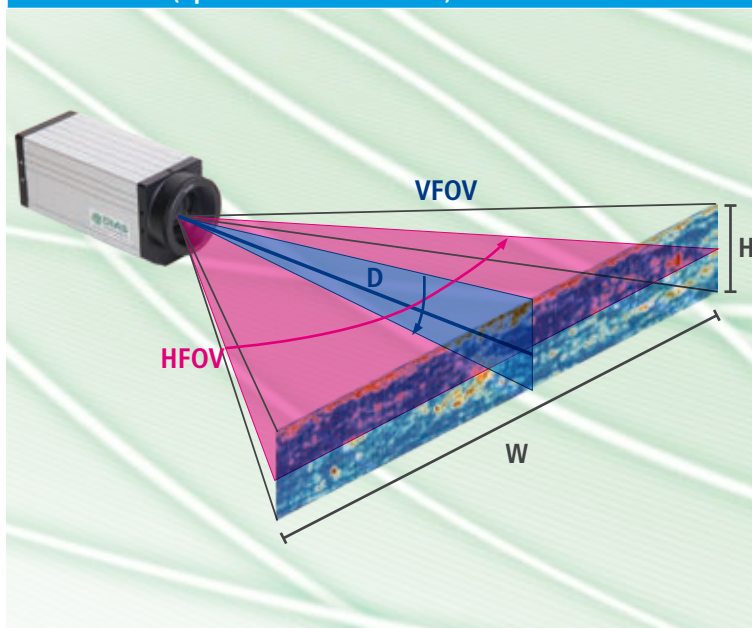

HFOV × VFOV IFOV	D [m]	W [mm]	H [mm]
36° × 0.15° 1.2 mrad	1	640	2.5
	3	1920	7.5
90° × 0.34° 3 mrad	1	2000	7.8
	3	6000	23.4
51° × 0.2° 1.7 mrad	1	960	3.8
	3	2880	11.3
19° × 0.08° 0.7 mrad	1	334	1.3
	3	1002	3.9
13° × 0.05° 0.4 mrad	1	219	0.9
	3	658	2.6
9° × 0.04° 0.3 mrad	1	154	0.6
	3	461	1.8
	10	1536	6

HFOV ... Horizontal Field Of View (horizontal aperture angle)

W ... Image width

VFOV ... Vertical Field Of View (vertical aperture angle)

H ... Image height

IFOV ... Instantaneous Field Of View (spatial resolution)

D ... Measurement distance

# PYROLINE HS 512N/2000 Hz

High-speed non-contact measurement of temperature profiles up to 3000 °C

## Dimensional drawings

### Dimensions: PYROLINE HS 512N in compact+ housing

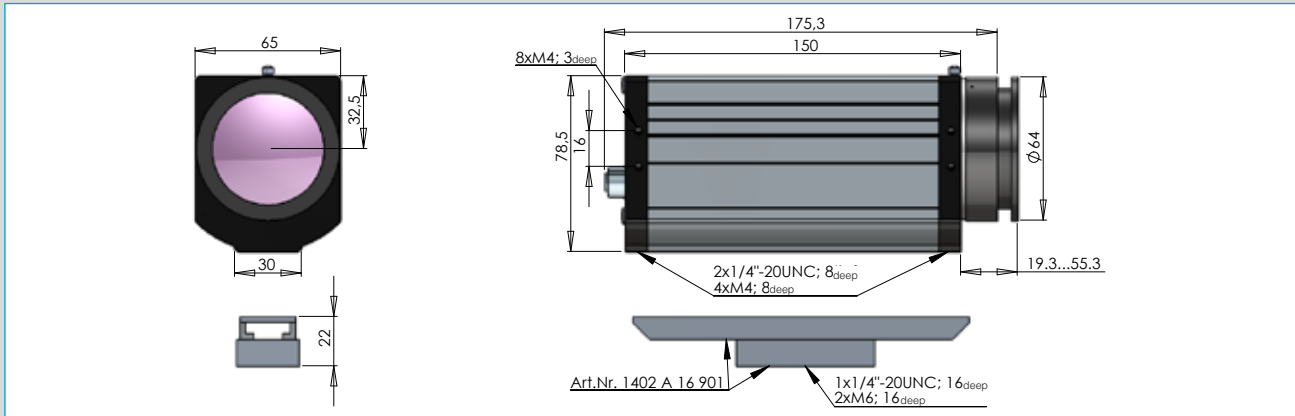

### Dimensions: PYROLINE HS 512N in protection housing

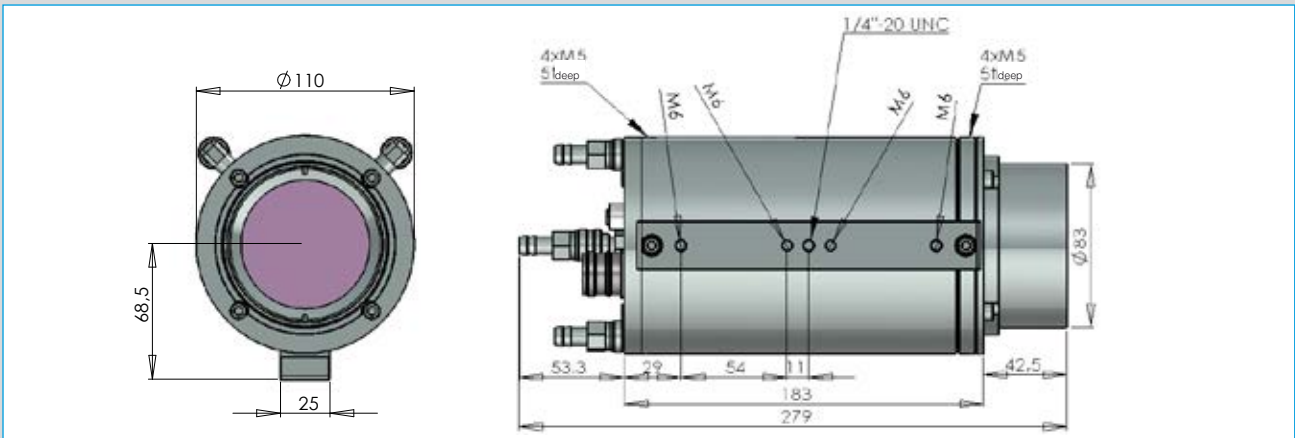

## Connectors

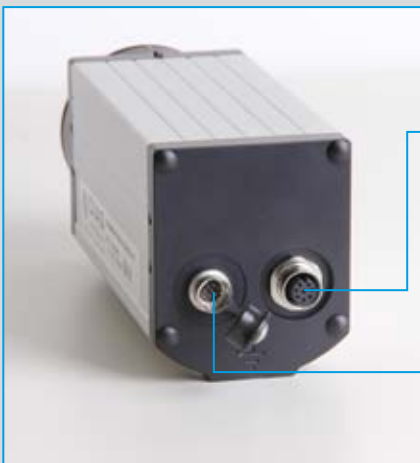

### Fast Ethernet (LAN)

- Infrared real-time data up to 2000 lines per second (TCP/UDP)
- Web interface (status and image bar)
- PYROSOFT software
- GigE Vision™ compatible
- Configuration for stand-alone operation

➔ Power supply	Error signal/
➔ Trigger 1	Alarm 1 ➔
➔ Trigger 2	Synch signal/
	Alarm 2 ➔
<b>Inputs</b>	<b>Outputs</b>

### Customized terminal box

(with power supply unit, alarm relay, controller, media convertor,...)

## Accessories<sup>1</sup>

Accessories <sup>1</sup>	Part number
Ethernet cable (8 pin) M12-RJ45/Cross/5 m	2301A32005
Connection set for Ethernet interface 8 pin for compact+ housing	2301A04101
Mounting set for compact+ housing	1402A16901

<sup>1</sup> More accessories available.

# PYROSOFT

Powerful online and offline software for DIAS infrared cameras

## PYROSOFT Brake

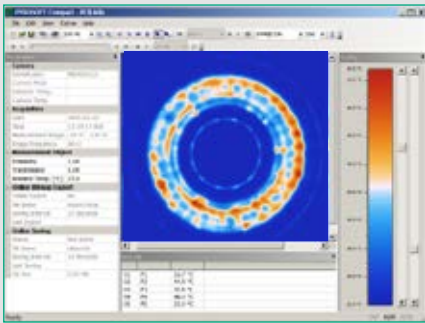

- Online data acquisition of one DIAS infrared camera
- Open and edit archived measured data and sequences
- Bitmap and video export
- Online data storage and online bitmap export
- Definition of regions of interests (ROI): points, lines and rectangle
- Generating of reports in Microsoft® Word format by integrated report function
- Context-sensitive help system (F1 key)
- Rotation representations of a brake disc

## PYROSOFT Professional

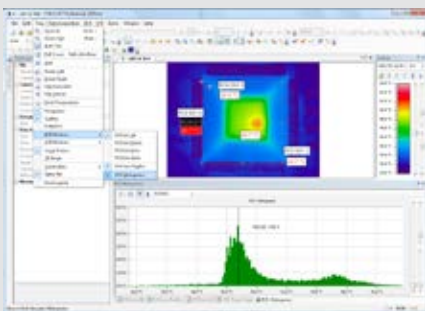

- Online data acquisition – Analyze, store and export data in real-time
- Open and edit archived measured data and sequences
- Multi document structure for several documents
- Bitmap, video and text export
- Definition of regions of interests (ROI) and values of interests (VOI) with alarm calculation, histogram and trend chart
- Numerous interface possibilities for processes (PROFIBUS, PROFINET, WAGO, TCP-Socket, Text IO)
- Reporting function, context-sensitive help system (F1 key)
- PYROSOFT Professional IO offers optionally a bidirectional data interface via PROFIBUS, PROFINET, WAGO, MODBUS, OPC, TCP Socket to process control systems, controllers and other applications

## PYROSOFT Automation

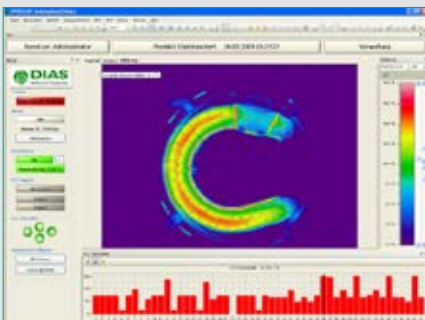

DIAS has developed the software PYROSOFT Automation for the integration of infrared cameras in automation processes.

- Comfortable product management with free definable document templates
- Product choice and release control can be made manually or automatically
- Different user levels for operator, tool setter and administrator
- Functionality of PYROSOFT Professional for administrators
- Automatic logging of system messages, measured data and alarms
- Easy to use and configurable user interface for application in fabrication
- Learning functions for automatic adjustment of alarm threshold
- Offline viewer for belated data analysis
- Bidirectional data interface via PROFIBUS, PROFINET, WAGO, MODBUS, OPC, TCP Socket to process control systems, controllers and other applications

## PYROSOFT DAQ



For users who want to make an integration into their software environment by themselves, we offer an own online and offline DLL interface for DIAS infrared cameras.

- API (DLL) for direct data access under Windows®
- Support for DIAS IRDX file format
- Setting of data acquisition parameters and object properties
- Query of temperature values and camera information
- Functions for displaying of images and palettes as bitmap
- Online and offline function

More software packages are available, for example:

PYROSOFT MultiCam (process software for monitoring up to 8 cameras), PYROSOFT CamZone (software for programming a stand-alone camera), application specific software like PYROSOFT FDS for DIAS fire detection systems.